

CPS 175 – 100
Portable compressor



People. Passion. Performance.



Standard Scope of Supply

The Chicago Pneumatic **CPS 175 – 100 T4F** is single-stage, oil-injected, rotary screw type air compressors, powered by a liquid-cooled, four-cylinder turbocharged Kubota diesel engine.

The unit hosts the new generation C67 Screw element in its air end combined with a Kubota made diesel engine model V1505-CR-T-E5B, complying with the T4F emission standard.

Special attention has been given to the overall product quality, user friendliness, ease of serviceability, and economical operation to ensure best in class cost of ownership.



Features

- Compact, fuel-efficient engine
- Designed with environmental protection in mind
- Compact, sound attenuated, corrosion resistant enclosure
- RedRock™ hood and 3-layer painting of metal parts

Benefits

- Saves up to 25% of fuel on typical applications in this range compared to its Stage IIIA predecessor (at 50% load).
- The unit comes with a Spillage Free frame as Standard with 110% fluid containment and T4F emission compliant engine.
- For EPA compliance the unit is enclosed in a sound attenuated clam shell type canopy.
- Compact and maneuverable, saving valuable space on your job site, and during transportation.
- High residual value and low repair costs.

Main Data

Model		CPS 175 - 100
Minimum effective receiver pressure	psi(g)	72
Maximum effective receiver pressure (Unloaded)	psi(g)	125
Normal effective working pressure	psi(g)	100
Actual free air delivery	CFM	170
Fuel consumption		
at 100% FAD (full load)	gal/h	2.1
at 75% FAD	gal/h	1.48
at 50% FAD	gal/h	1.01
at 25% FAD	gal/h	0.85
Maximum typical oil content of compressed air	ppm	5
Max. sound power level (Lw @ 2000/14/EC)	dB(A)	98
Max. sound pressure level (Lp @ ISO 2151)	dB(A)	70
Max. ambient temperature at sea level	°F	122
Min. starting temperature with cold start equipment	°F	-4

Engine		Kubota
Type		V1505-CR-T-E5B
Emission stage		T4F
Coolant		ParCool Green
Number of cylinders		4
Bore	mm	78
Stroke	mm	78.4
Swept volume	l	1.498
Engine power at normal shaft speed @ ISO 9249G	kW (HP)	33 (44)
Full Load	rpm	3000
Unload	rpm	1800
Capacity of oil sump:	gal	1.45
Capacity of cooling system	gal	2.1
Capacity of compressor oil system	gal	2.1
Net capacity of air receiver	gal	3.2
Capacity of standard fuel tanks	gal	15.8
Safety valve - minimum opening pressure	psi(g)	142

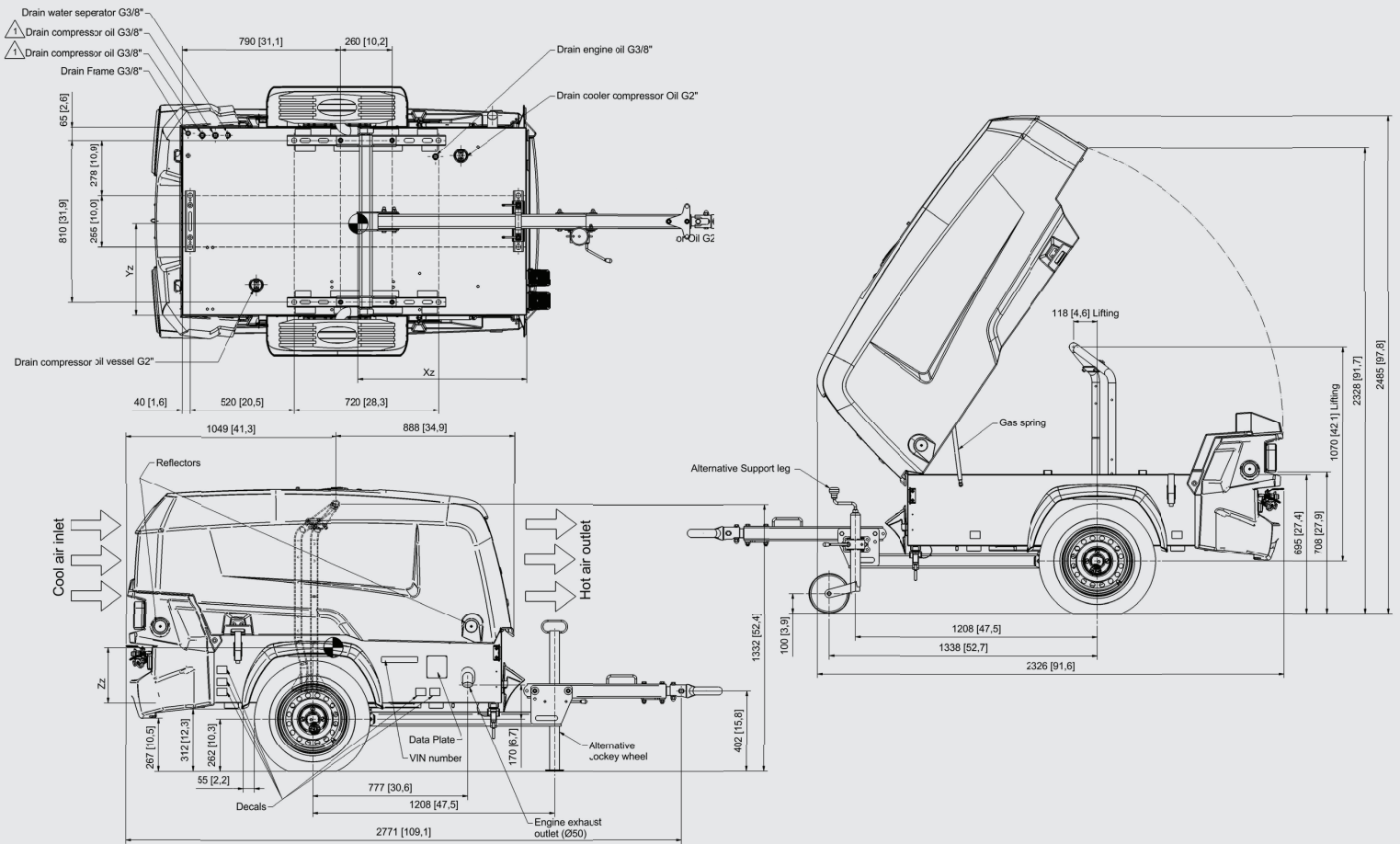

Weight (Wet-Ready-to-operate)

		CPS 185 Kohler
Trailer mounted	lb(kg)	1638 (743)

Dimensions

		CPS 185 Kohler
Trailer mounted - Inches (m)	L x W x H	117.1 (2974) x 53 (1346) x 55.9 (1419)

Principle Data

Compressor Element

The quality of a compressor can be measured through the reliability, efficiency and durability of the compressor element used. Through decades of expertise in the design of compressor elements, the result is the production of most efficient and reliable compressors in the market. When the screw element is efficient durability excels, maintenance intervals decrease and fuel consumption goes down.

The CPS 175 – 100 compressor utilizes C67 element and is driven from the diesel engine. Inlet air is filtered through a heavy duty two stage air filter.

Air/Oil Separator

Air and oil separation is achieved through a centrifugal oil separator combined with a filter element. The vessel is ASME/CRN approved and stamped accordingly.

Designed for a higher maximum working pressure, the separator is equipped with a high pressure sealed and certified safety relief valve (automatic blow-down valve).

Cooling System

The cooling system consists of integrated side-by-side aluminum coolers with an axial fan to ensure optimum cooling. The fan is protected by a guard for operator safety. There is an access port for easy cleaning of coolers.

The cooling system is suitably designed for continuous operation in ambient conditions up to 122°F, with canopy doors closed.

Engine

Kubota

A Kubota V1505-CR-T-E5B common rail turbocharged four-cylinder, liquid-cooled diesel engine provides ample power to operate the compressor continuously at full load.

Cold start options are available for temperatures down to -4°F.

The 15.8 gallons fuel tank is sufficiently sized to allow 8 hours autonomy at 75% load.

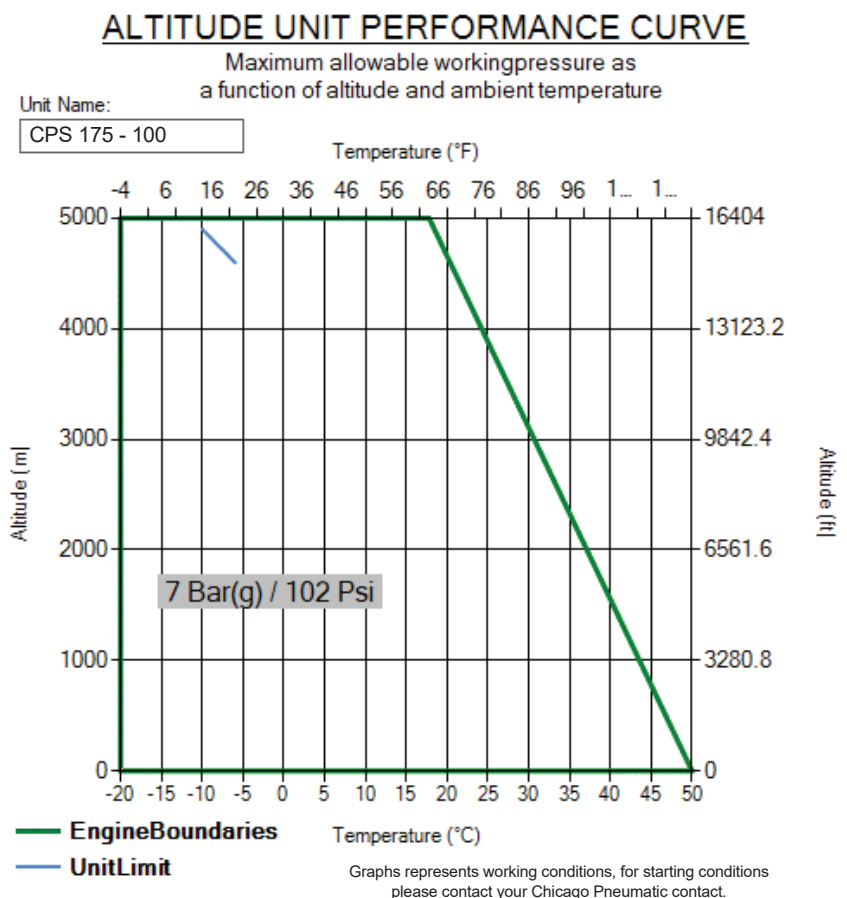



Electrical System

The CPS 175 - 100 is equipped with a 12 Volt negative ground electrical starting system.

Instrumentation

The instrument control panel is located on the back, of the compressor canopy with easy access. Standard instrument package includes an operating pressure gauge, and fully diagnostic ECU controller with large 3.5" display. The intuitive XC1004 controller is easy to operate with all functions conveniently at your fingertips. The controller also manages the engine ECU operating system, and a number of safety warnings and shut downs on various parameters (listed below).

XC1004 Controller Functionality:



Displayed while running

- Hours
- Fuel level
- RPM
- Outlet pressure



Operational Buttons

- Start and stop of the unit
- View measurements, settings and alarms
- Graphical representations of the alarms



Compressor measurements displayed

- Running hours
- Fuel level
- Battery voltage
- Running hours
- Regulating pressure
- Minor and major service counters in hours and days
- Compressor element temperature



Warnings and Shutdowns

- High temperature engine coolant
- High temperature compressor oil
- Engine oil pressure
- Low fuel level



Settings

- Reset service timers
- Diagnostics for engine ECU
- Unit of measure changes



Engine measurements displayed

- Current fuel level
- Engine coolant temperature
- Engine oil pressure
- Engine RPM



Alarms

- View current & historical alarms present
- DM1: View current engine codes (SPN/FMI)





Bodywork

The compressor's frame comes standard with ASTM A653 Zincor steel platework with powder coat paint finish providing excellent corrosion protection. The canopy is sound attenuated to meet the most current legal noise requirements.

Undercarriage

The **CPS 175 - 100** is available with undercarriage alternatives, providing utmost flexibility in installation or towing requirements.

Single axle trailer setup with:

- US DOT/Federal MVSS 49CFR571 approved light package and Peterson B5400A 4-way trailer connector
- Adjustable height pintle hitch (3" lunette)
- 13" Rims w/155R13 Tires for trailer use
- Trailer brakes not standard
- Heavy Duty torsion axle rated at 1,875 lbs
- Safety chains
- Jockey wheel leveling
- Single point lifting structure

Undercarriage options:

- Loose Ball Coupling 2 5/6"
- Loose Ball Coupling 2"
- Loose Ball Coupler 2" Bulldog

Manufacturing & Environmental Standards

The **CPS 175 - 100** is manufactured following stringent ISO 9001 regulations, and by a fully implemented Environmental Management System fulfilling ISO 14001 requirements.

Attention has been given to ensure minimum negative impact to the environment.

The CPS 175 Kubota meets all current US EPA, CARB and Environment Canada exhaust and noise emission directives.



Supplied Documentation

The unit is delivered with documentation regarding:

- Hard copies of the Chicago Pneumatic Operators Safety and Instruction Manual, as well as electronic copies available on request.
- Certificate for air/oil separator vessel and safety valve approval, ASME/CRN, Chicago Pneumatic Parts Book (Upon request only).

Warranty Coverage

Chicago Pneumatic Compressor: Warrantied to be free from defects with regard to material and workmanship for the period of eighteen (18) months from date of shipment from the factory, or twelve (12) months from date of initial start-up, whichever occurs first, without limitation of running hours.

Air compressor element assemblies used in Chicago Pneumatic portable air compressors, is warranted to be free from defects with regard to materials and workmanship for the period of thirty (30) months from date of shipment from the factory, or twenty-four (24) months from date of initial startup, whichever occurs first, without limitation of running hours. Chicago Pneumatic service kits including parts and oils (GENOil's) must be used to maintain warranty. Failure to register warranty upon initial start-up may cause warranty claim delays or rejection of claims.

Extended Warranty Programs: Programs are available; please contact your local sales representative for more info.

For more information, please contact your CP partner:

Use only Chicago Pneumatic parts. Any damage or malfunction caused by the use of unauthorized parts is not covered by Warranty or Product Liability.

© 2023 Chicago Pneumatic. Subject to technical modifications.



www.cp.com