

Preliminary

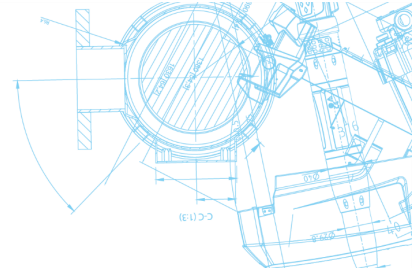

The XAS 400–150, XAS 400–200 compressor range with PACE technology

Caterpillar high performance engine (400 cfm)



Standard features

The Atlas Copco XAS 400 range is a single-stage, oil-injected, rotary screw type air compressor, powered by a liquid-cooled, four-cylinder turbocharged T4F diesel engine.

The unit consists of an air end, diesel engine, cooling circuit, air/oil separation and PACE control systems - all enclosed within a sound dampening HardHat™ enclosure.

Factory and locally installed options are available including a range of undercarriages.

The design focus is overall product quality, user friendliness, ease of serviceability, and economical operation to ensure best in class cost of ownership.



Preliminary

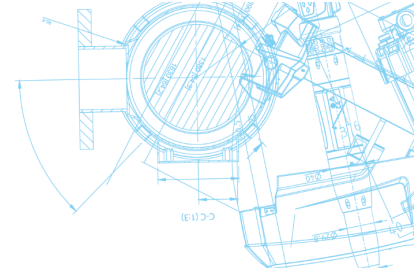

Pressure and Flow

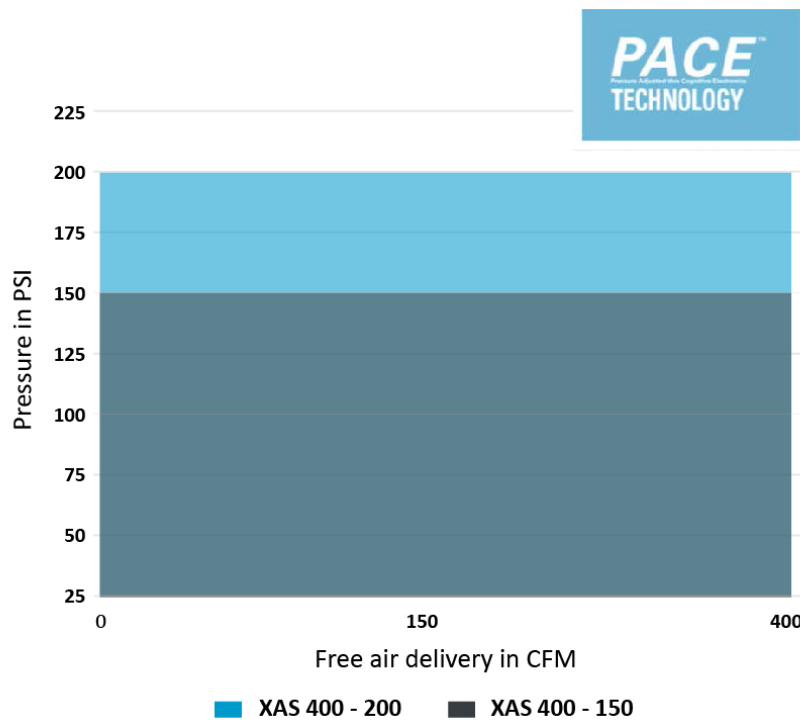

Available models

XAS 400 – 150 PACE

XAS 400 – 200 PACE

single stage – 100 to 150 psi – Caterpillar engine

single stage – 100 to 200 psi – Caterpillar engine

Features	Benefits
<ul style="list-style-type: none"> Caterpillar T4F engine 	<ul style="list-style-type: none"> Meets all current T4F emission regulations. Integrated exhaust aftertreatment makes T4F integration easy. Extended warranty available through caterpillar dealer.
<ul style="list-style-type: none"> Atlas Copco Controller XC2003 PACE Pressure Adjusted through Cognitive Electronics 	<ul style="list-style-type: none"> Proven controller for easy operation and diagnostics of the compressor and engine. Allows operator to view compressor parameters including: Pressure settings, reading engine codes, two programmable service timers, all temperatures and pressure of compressor, fuel levels and consumptions, and load/unload compressor.
<ul style="list-style-type: none"> Low Fuel Shutdown 	<ul style="list-style-type: none"> Reduces downtime on site when operator runs out of fuel as there is no longer a need to “re-prime” the fuel system.
<ul style="list-style-type: none"> Heavy Duty Single Axle Trailer w/15” tires 	<ul style="list-style-type: none"> Well balanced for safer towing or moving around site High ground clearance for rough site and road conditions
<ul style="list-style-type: none"> HardHat™ enclosure 	<ul style="list-style-type: none"> Heavy ¼” double wall polyethylene enclosure Dent and UV Resistant Keeps looking new for longer and adds to resale value
<ul style="list-style-type: none"> Cold Weather Package 	<ul style="list-style-type: none"> Features required for reliable cold weather operation. Including: synthetic compressor oil (Paroil S) and block heater.
<ul style="list-style-type: none"> 110% Spillage Free Containment Frame 	<ul style="list-style-type: none"> Protects environment from spill/leaks, avoids costly clean up
<ul style="list-style-type: none"> New Oil Separator Tank design 	<ul style="list-style-type: none"> Filter surface increased from 2000 to 2450 cm² Easy to service
<ul style="list-style-type: none"> Aftercooler, water separator with UD filters 	<ul style="list-style-type: none"> Provides cool, dry, clean air for applications where instrument quality air is required.



Preliminary

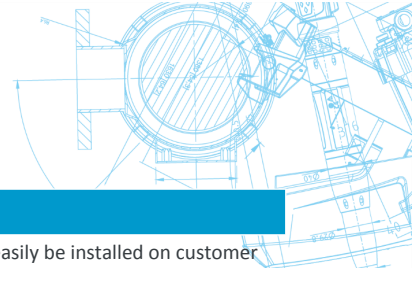

Options	Benefits
<ul style="list-style-type: none"> SKID 	<ul style="list-style-type: none"> Perfect for OEM applications, can easily be installed on customer trailer
<ul style="list-style-type: none"> FleetLink 	<ul style="list-style-type: none"> With FleetLink, you'll have the latest information concerning your fleet's performance at hand. Anytime, Anywhere. Track and Monitor fleet performance and utilization. Detect service needs. Monitor fuel and DEF consumption
<ul style="list-style-type: none"> Fork Lift Slots 	<ul style="list-style-type: none"> To be safely maneuvered with fork lift.
<ul style="list-style-type: none"> External Toolbox 	<ul style="list-style-type: none"> Safely and securely store your tools
<ul style="list-style-type: none"> Hose Reel 	<ul style="list-style-type: none"> Conveniently store your hoses on the compressor tongue.
<ul style="list-style-type: none"> Battery cut off switch 	<ul style="list-style-type: none"> Extend your battery life time by stopping residual draw from the battery when machine not used.
<ul style="list-style-type: none"> External Fuel Tank Connection 	<ul style="list-style-type: none"> 3 Way valve and fittings for external fuel connection
<ul style="list-style-type: none"> Air Inlet shutdown Valve 	<ul style="list-style-type: none"> Engine air inlet valve

Technical Data

Compressor		XAS 400-150 PACE		XAS 400-200 PACE	
Actual free air delivery ¹ (FAD)	Cfm	400	400	400	395
Normal effective working pressure	Psi	100	150	150	200
Minimum working pressure	Psi	58		58	
Max. sound pressure level @ 23' (7m) at normal working speed & pressure ²	dB(a)	82.6		83.6	
Compression Stages		1		1	
Air Receiver Capacity	US Gal (L)	11 (41.6)		11 (41.6)	
Compressor oil capacity	US Gal (L)	6.75 (25.55)		6.75 (25.55)	
Approximate air outlet temperature (not aftercooled)	°F (°C)	200 (93)		200 (93)	
Air Compressor outlets		2 x ¾" & 1 x 1 ½"		2 x ¾" & 1 x 1 ½"	
Max. ambient temperature (at sea level) ³	°F (°C)	118 (47.78)		116 (46.67)	
Maximum altitude	Ft (m)	11,820 (3,602)		11,820 (3,602)	
Minimum starting temperature (cold weather)	°F (°C)	-13 (-25)		-13 (-25)	

Engine	Caterpillar	C4.4	C4.4
Emissions Regulation	US EPA Tier	T4F	T4F
Output at rated speed (2400 rpm)	HP	148	148
Number of cylinders		4	4
Aspiration		Turbocharged	Turbocharged
Displacement	cu in (L)	269 (4.5)	269 (4.5)
Engine speed (Unloaded)	Rpm	1500	1500
Engine speed (Maximum loaded)	Rpm	2200	2200
Engine oil capacity	US Gal (L)	9 (34.07)	9 (34.07)
Engine oil required		10W30	
Engine coolant capacity	US Gal (L)	5.6 (21.3)	6.25 (23.6)
Fuel tank capacity	US Gal (L)	52 (197)	52 (197)
Fuel consumption at 0% load	Gal/Hr (L/Hr)	1.58 (5.98)	1.58 (5.98)
Fuel consumption at 100% load	Gal/Hr (L/Hr)	5.96 (22.56)	5.96 (22.56)
DEF tank capacity	US Gal (L)	5 (18.9)	5 (18.9)
DEF consumption at 100% load	Gal/Hr (L/Hr)	TBD	TBD
Battery Capacity (Cold Cranking Amps ⁴)	A	1150	1150

¹ According to ISO 1217 ed.3 1996 annex D

² Measured in accordance with ISO 2151 under free field conditions @ 7m distance

³ Consult Atlas Copco for proper de-rating instructions for operation beyond ambient limitations

⁴ According to DIN 72311



Preliminary

Dimensions

Trailer mounted

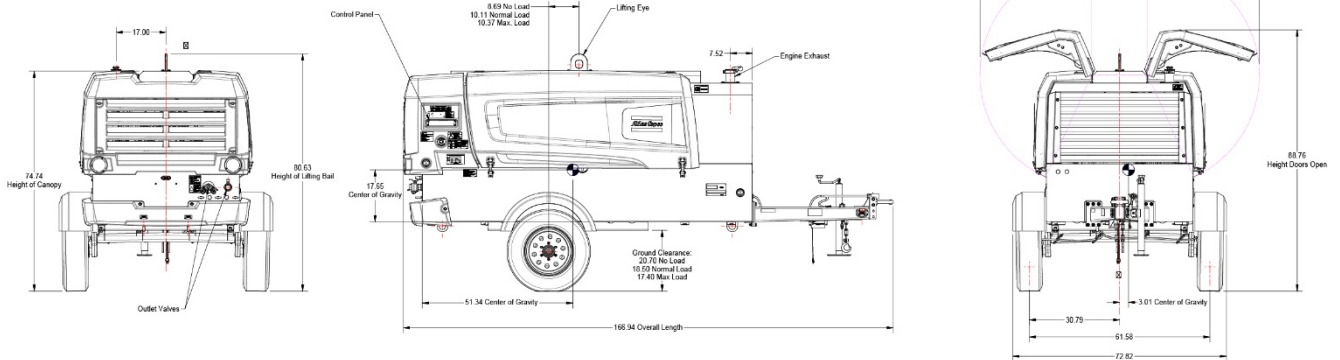

Support mounted

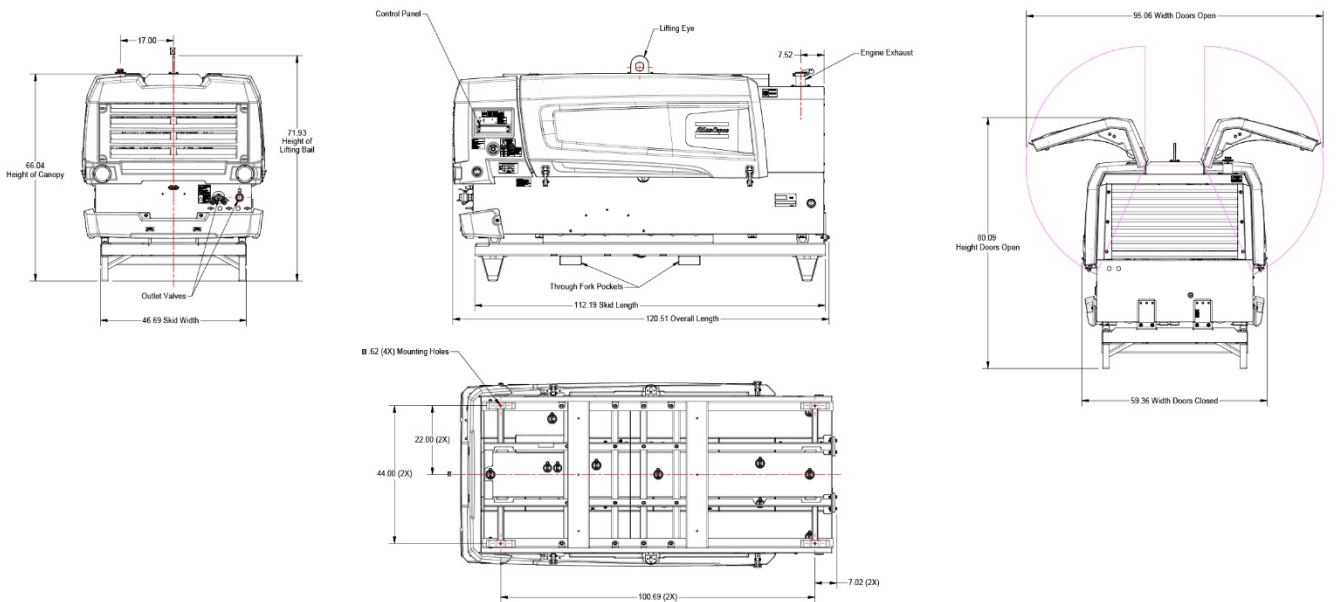

Weight (Wet - Ready-to-operate)

		XAS 400-150 PACE	XAS 400-200 PACE
Trailer mounted	lb (Kg)	4725 (2143.22)	4725 (2143.22)
Support mounted	lb (Kg)	4710 (2136.42)	4710 (2136.42)

Dimensions

		XAS 400-150 PACE	XAS 400-200 PACE
Trailer mounted (Inches)	L x W x H	166.94 x 72.82 x 80.63	166.94 x 72.82 x 80.63
Support mounted (Inches)	L x W x H	120.5 x 59.36 x 71.93	120.5 x 59.36 x 71.93

Principle Data

Preliminary

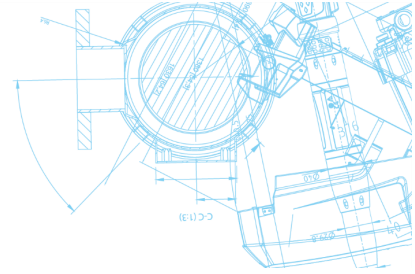

New Design Vessel

- Filter surface increased from 2000 to 2450 cm²
- Easy to service:
 - No sensors, valves, hoses at vessel lid
 - Low weight vessel lid
 - No need to dismount scavenge line
 - Bolt at top of OSE ensures proper grounding and firm connection
 - Handle integrated in top plate of OSE
 - Springs at bottom of OSE for grounding

Compressor Element

The quality of a compressor can be measured through the reliability, efficiency and durability of the compressor element used. Through decades of expertise in the design of compressor elements, Atlas Copco remains a world leader in designing the most efficient and reliable compressors on the market. With air-end efficiency, maintenance intervals are extended and fuel consumption is reduced.

The XAS 400 range compressor utilizes Atlas Copco's C106 element and is driven from the diesel engine through a gear box with a rubber disc coupler.

The compressor system comes with Atlas Copco ParOil S compressor oil. The oil cooler comes equipped with a standard thermostatic by-pass valve for superior cold weather lubrication.

Air/Oil Separator

Air and oil separation is achieved through a centrifugal oil separator combined with a filter element. Separators are available in ASME/CRN approved versions and are stamped accordingly.

Designed for a higher maximum working pressure, the separator is equipped with a sealed high pressure safety relief valve, minimum pressure valve, automatic blow-down valve, and pressure regulator.

Air/Oil Separator Tank:

Volume	11 US Gal / 42 L
Certifications	ASME / CRN
MAWP	261psi @ 266°F

Cooling System

The cooling system consists of integrated side-by-side aluminium oil cooler with axial fan to ensure optimum cooling. The cooling system is suitably designed for continuous operation in ambient conditions up to 125°F, with canopy door closed.

Compressor Regulating System



Preliminary

The compressor regulating system consists of an air filter, air receiver/oil separator, compressor element, unloader assembly with unloader valve, blow down valve and loading valve.

Economic power consumption is assured by the fully automatic 100% step-less speed regulator that adapts engine speed to air demand.

Discharge Outlets

Compressed air is available from (2) 3/4" claw type (Chicago) outlet valves and (1) 1 1/2" NPT valve.

Engine

Caterpillar C4.4

Caterpillar C4.4 T4F turbo charged four-cylinder, liquid-cooled diesel engine provides ample power to operate the compressor continuously at full-load.

Meets all US EPA and Environment Canada exhaust legislations with Final Tier 4 compliance.

US EPA engine family is "HPKXL04.4MT1" and rated at 148hp at 2200 rpm, in accordance to SAE Standard for the XAS 400-150 CD T4F.

US EPA engine family is "HPKXL04.4MT1" and rated at 148hp at 2200 rpm, in accordance to SAE Standard for the XAS 400-200 CD T4F.

Engine starting capacity at -13°F (-25°C) without the addition of cold start options.

The 52Gal (192L) fuel tank enables operation for over 8 hours at full load and comes standard with a low fuel shutdown at 6%.

Altitude Curve

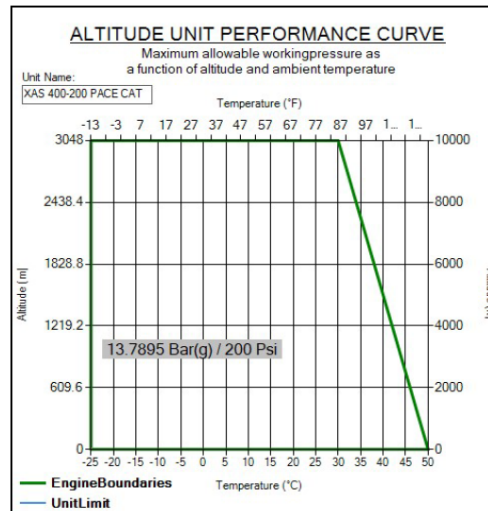
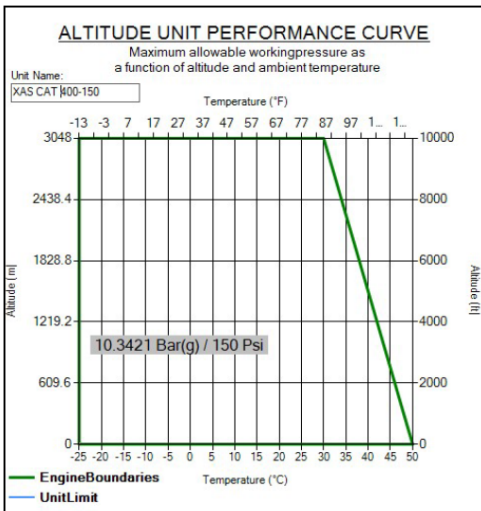

Emissions Treatment

Caterpillar C4.4 T4F engine after treatment consists of a Diesel Oxidization Catalyst (DOC) and Selective Catalytic Reduction (SCR).

Electrical System

Preliminary

The **XAS 400 range** is equipped with a 12 Volt negative ground electrical starting system.

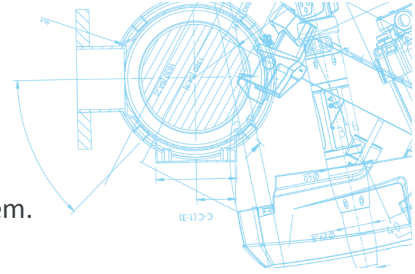

Instrumentation

The instrument control panel is located on the back, of the compressor canopy with easy access.

Standard instrument package includes fully diagnostic ECU controller with large 3.5" display. The intuitive Atlas Copco XC2003 controller is easy to operate with all functions conveniently at your fingertips. The controller also manages the engine ECU operating system, and a number of safety warnings, shut downs on various parameters (listed below) and full digital pressure control with PACE.

XC2003 Controller Functionality:

- Displayed while running
 - Hours
 - Fuel level
 - RPM
 - Outlet pressure
- Compressor measurements displayed
 - Running hours
 - Fuel level
 - Clock
 - Battery voltage
 - Running hours
 - Regulating pressure
 - Emergency stop count
 - Average fuel consumption
 - Minor and major service counters in hours and days
- Warnings and Shutdowns
 - High temperature engine coolant
 - High temperature compressor oil
 - Engine oil pressure
 - Low fuel level
 - Low coolant
- Settings
 - Reset service timers
 - Diagnostics for engine ECU
 - Language settings
 - Unit of measure changes
 - Electronic pressure adjustment (**PACE**)
 - Presetting two (high/low) pressure settings
- Operational Buttons
 - Start and stop of the unit
 - View measurements, settings and alarms
 - Multi position cursor to navigate menus
 - PACE digital pressure control
- Engine measurements displayed
 - Current fuel rate
 - Engine coolant temperature
 - Engine oil pressure
 - Engine RPM
- Alarms
 - View current & historical alarms present
 - History of last 20 alarms and events with time and date stamps
 - DM1 & DM2: View current engine codes (SPN/FMI)

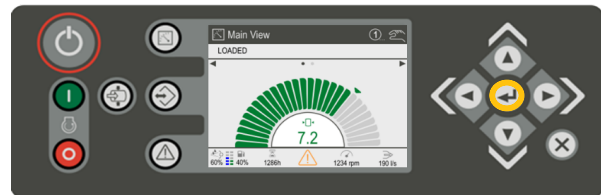

Bodywork

HardHat™: Our HardHat™ version comes standard with dual wall, 0.2" thick, Polyethylene material providing superior corrosion, and UV protection against fading and discoloration. As well as unmatched dent and damage resistance. The canopy is sound attenuated to meet the most current legal noise requirements. A clamshell style hood offers easy service access to all components.

Undercarriage



Preliminary

The **XAS 400 range** is available with two undercarriage alternatives, providing utmost flexibility in installation or towing requirements.

- Single axle trailer setup with:
 - DOT approved light package
 - Adjustable height pintle hitch (3" lunette)
 - 5,200 lbs torsional axle
 - 15" Rims w/ ST225/75D15 8 Ply Tires (weight rating 2,540 lbs @ 65psi)
 - Electric trailer brakes as standard (with 7 pin flat blade connector)
 - 750lbs jack leg stand
 - Tongue weight 485 lbs

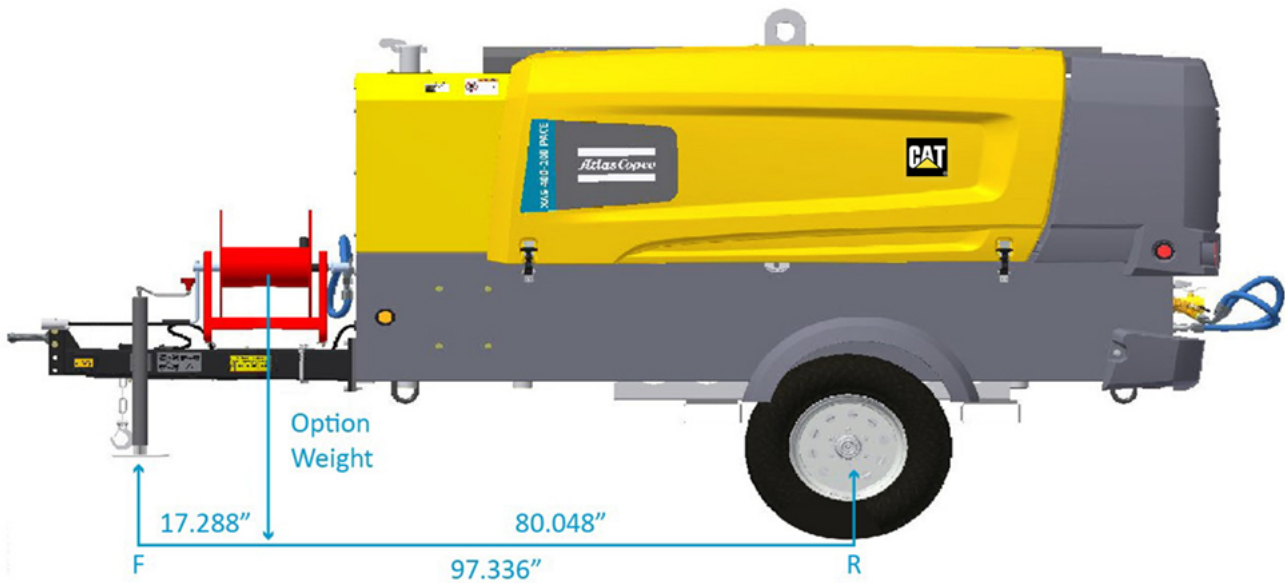

Constants	Value	Units
Distance from Axle to Jack Stand	97.34	inches
Distance from Jack Stand to Option	17.29	inches
Distance from Option to Axle	80.05	inches
Standard Jack Stand Load	485.00	pounds

Options	Weight of reel or box	Weight of base	Total weight	Moment at stand	Additional load at stand	Total load at stand
Units	pounds	pounds	pounds	in*pounds	pounds	pounds
Hose Reel 50'	41.00	22.68	63.68	5097.71	52.37	537.37
Hose Reel 50' Double	82.00	22.68	104.68	8379.69	86.09	571.09
Hose Reel 100'	46.00	34.70	80.70	6459.89	66.37	551.37
Hose Reel 100' Double	92.00	34.70	126.70	10142.11	104.20	589.20
Tool Box	109.41	34.70	144.11	11536.10	118.52	603.52

Preliminary

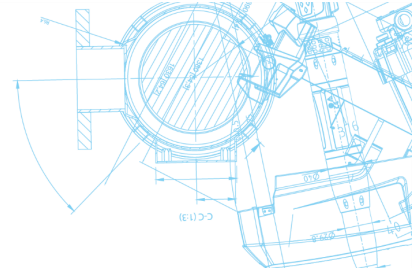

Undercarriage Options

- Support Mounted (skid)
- Loose Ball Coupling 2" or 2.5/16"
- OSHA ¾" Valves
- Fork Lift Pockets
- Jockey Wheel
- Hose reel
 - 50 ft. single live hose reel
 - 100 ft. single live hose reel
 - 50 ft. dual live hose reel
 - 100 ft. single live hose reel

Manufacturing & Environmental Standards

The 400 Series CD T4F is manufactured following stringent ISO 9001 regulations, and a fully implemented Environmental Management System fulfilling ISO 14001 requirements.

Attention has been given to ensure minimum negative impact to the environment.

The 400 Series CD T4F meets all current EPA and Environment Canada exhaust and noise emission directives.

Supplied Documentation

The unit is delivered with documentation regarding:

- Hard copies of the Atlas Copco Operators Safety and Instruction Manual, Caterpillar Engine Manual and Parts book, as well as electronic copies, available upon request.
- Warranty Registration card for Caterpillar Engine and Atlas Copco Compressor (Unit must be registered upon receipt).
- Test certificate for air delivery pressure and capacity, acc. ISO 1217 (Upon request only).
- Certificate for air/oil separator vessel and safety valve approval, ASME (Upon request only).

Warranty Coverage

Caterpillar Engine: Please refer to the specific Engine OEM for warranty terms and conditions.

Atlas Copco Diesel Driven Compressor: Warrantied to be free from defects with regard to material and workmanship for the period of eighteen (18) months from date of shipment from the factory, or twelve (12) months from date of initial start-up.

Air compressor element assemblies used in Atlas Copco portable air compressors, are warranted to be free from defects with regard to materials and workmanship for the period specified in the Warranty Statement document. Atlas Copco service kits, including parts and oils (PAR Oil's), must be used to maintain warranty. Failure to register warranty upon initial start-up may cause warranty claim delays or rejection of claims.

Extended Warranty options are available. Please see Warranty Statement for term and conditions.

